

FITTING INSTRUCTION

Clamp mark in acc. with		Cables joining
ISO	PN	
1	L	Left directional lights
2	+	Rear fog lights
3	31	Ground
4	R	Right directional lights
5	58R	Right side parking lights
6	54	Stoplights
7	58L	Left side parking lights

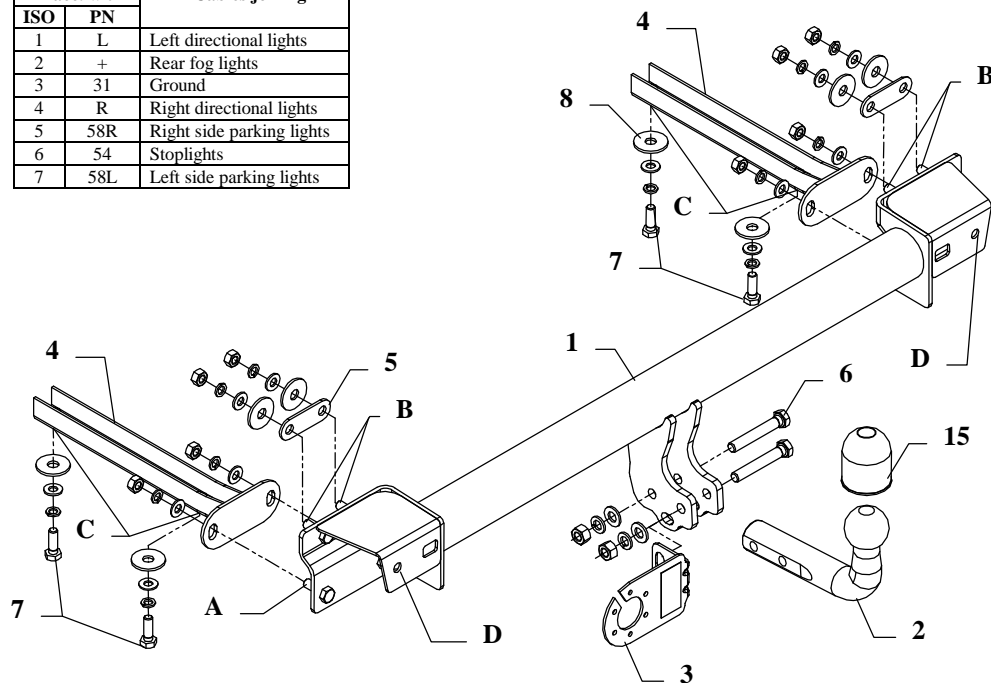

This towing hitch is designed to assembly in following cars:
BMW 3 Series E30, 4 doors, Coupe, produced since 08.1982 till 12.1990,
BMW 3 Series E30, Estate, produced since 08.1987 till 12.1993, catalogue no. **B01** and is prepared to tow trailers max total weight **1400 kg** and max vertical load **75 kg**.

From manufacturer

Thank you for buying our product. Their reliability has been confirmed in many tests. Reliability of towing hitch depends also on correct assembly and right operation. For this reasons we kindly ask to read carefully this instruction and apply to hints.

The towing hitch should be install in points described by a car producer.

The instruction of the assembly

- For the purpose of installings towing hitch one ought to disassemble the bumper
 - for vehicles produced since 1983 till 06.1988 untwist industrial handles fastening (Attention: the narrow bumper).
 - for vehicles produced since 06.1988 till 1990 unscrew industrial handles fastening, the internal fulfillment of the bumper and the external elastic protection (Attention: the wide bumper).
- To back piece apply the main bar of the towing hitch (pos. 1) and mark points (pos. A i B). In marked points drill holes $\varnothing 11\text{mm}$.
- Among well-made holes are situated perforated holes $\varnothing 46\text{mm}$ (on the left and right side of the piece), which one should perforate.
- Side brackets of the towing hitch (pos. 4) one ought to slip through perforated holes into chassis member and across existing holes of chassis members and holes (pos. C) twist loosely with bolts M10x30mm (pos. 7).
- Fix the main bar of the towing hitch (pos. 1) to the bumper through holes (pos. D)
 - for vehicles produced since 1983 till 06.1988 directly by means previously disassembled nuts.
 - for vehicles produced since 06.1988 till 1990 apply the main bar of the towing hitch (pos. 1) in the central part of the bumper and mark points (pos. D), then make holes in the bumper ($\varnothing 9\text{mm}$) and fix the main bar of the towing hitch (pos. 1) and put previously disassembled elastic protection.
- So prepared towing hitch apply to the back piece and fix with side brackets (pos. 4) through holes (pos. A) along with fish-plates (pos. 5) through holes (pos. B) using nuts M10.
- Fix tow-ball (pos. 2) and socket plate (pos. 3) by bolts M12x75mm (pos. 6) from accessories.
- Tighten all bolts according to the torque shown in the table.
- Connect electric wires of 7-poles socket according to the instruction of the car. (Recommend to make at authorized service station).
- Complete paint layer damaged during installation.

Torque settings for nuts and bolts (8,8):	
M 8 - 25 Nm	M 10 - 55 Nm
M 12 - 85 Nm	M 14 - 135 Nm



NOTE

After install the towing hitch you should get adequate note in registration book (at authorised service station).The car should be equipped with:

- Indicators
- Tow mirrors

After 1000km check all bolts and nuts. The ball of towing hitch must be always kept clear and conserve with a grease.

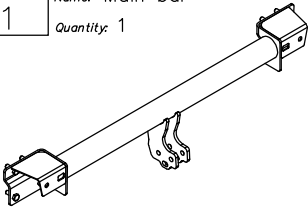
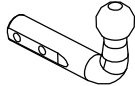
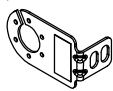
Towing hitch accessories:

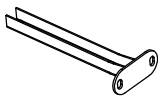
Pos. 1	Name: Main bar Quantity: 1	Pos. 5	Name: Fish-plate Quantity: 2 Dim.: 77x26x3mm	Pos. 10	Name: Nut 8 B Quantity: 8 Dim.: M10
		Pos. 6	Name: Bolt 8,8 B Quantity: 2 Dim.: M12x75mm	Pos. 11	Name: Plain washer Quantity: 2 Dim.: Ø 13 mm
		Pos. 7	Name: Bolt 8,8 B Quantity: 4 Dim.: M10x30mm	Pos. 12	Name: Plain washer Quantity: 12 Dim.: Ø 10,5 mm
Pos. 2	Name: Tow ball Quantity: 1	Pos. 8	Name: Washer Quantity: 8 Dim.: Ø35xØ12x3mm	Pos. 13	Name: Spring washer Quantity: 2 Dim.: Ø 12,2 mm
		Pos. 9	Name: Nut 8 B Quantity: 2 Dim.: M12	Pos. 14	Name: Spring washer Quantity: 12 Dim.: Ø 10,2 mm
Pos. 3	Name: Socket plate Quantity: 1			Pos. 15	Name: Ball cover Quantity: 1
					
Pos. 4	Name: Side bracket Quantity: 2				
					



PPUH AUTO-HAK S.J.

Produkcja Haków Holowniczych
Henryk & Zbigniew Nejman
76-200 SŁUPSK ul. Słoneczna 16K
tel/fax (059) 8-414-414; 8-414-413
e-mail: office@autohak.com.pl
www.autohak.com.pl

Towing hitch (without electrical set)

Class: **A50-X** Cat. no. **B01**

Designed for:

Manufacturer: **BMW**

Model: **SERIES 3 (E30)**

Type: **4doors, COUPE**

produced since 08.1982 till 12.1990

Type: **ESTATE**

produced since 08.1987 till 12.1993

Technical data:

D-value: 7,53 kN

maximum trailer weight: **1400 kg**

maximum vertical cup load: **75 kg**

Approval number according to Directive 94/20/EC: e20*94/20*0367*00

Foreword

This towing hitch is designed according to rules of safety traffic regulations. The towing hitch is a safety component and can be install only by qualified personnel. Any alteration or conversion of the towing hitch is prohibited and would lead to cancellation of design certification. Remove insulating compound and underseal from vehicle (if present) in the area of the matting surfaces of the towing hitch.

The vehicle manufacturer's specifications regarding trailer load and max. vertical cup load are decisive for driving, and values for the towing hitch cannot be exceeded.

D-value formula:

$$\frac{\text{Max trailer weight [kg]} \times \text{Max vehicle weight [kg]}}{\text{Max trailer weight [kg]} + \text{Max vehicle weight [kg]}} \times \frac{9,81}{1000} = D \text{ [kN]}$$